

DSP10

PILOT OPERATED DISTRIBUTOR SOLENOID OR HYDRAULIC (DSC10) CONTROLLED

SUBPLATE MOUNTING
ISO 4401-10 (CETOP 10)

p max 350 bar
Q max 1100 l/min

MOUNTING INTERFACE

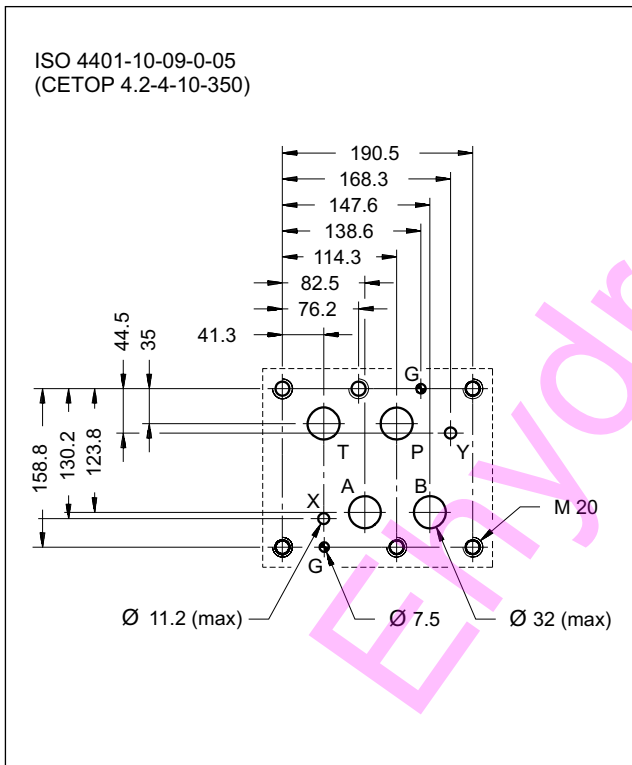

OPERATING PRINCIPLE

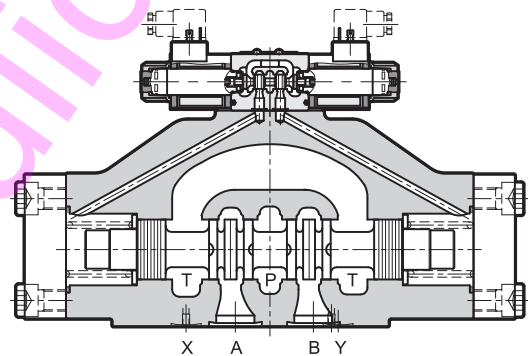

- The DSP10 piloted valve is a 4-way hydropiloted distributor with a connection surface in accordance with the ISO 4401-10 (CETOP RP121H) standards, operated by a ISO 4401-03 (CETOP 03) solenoid directional valve.
- It is available with different spool types (see par. 2) and with some options for the opening control.
- It is available with both the solenoid and the hydraulic control from the X and Y ways.
- The piloting and the drainage can be made inside or outside the valve by inserting or removing the proper threaded plugs located in the main directional control valve (see paragraph 9).

PERFORMANCES (obtained with mineral oil of viscosity of 36 cSt at 50°C)

Maximum operating pressure		
- ports P - A - B (standard version)		350
- port T (external drainage)	bar	210
Maximum flow rate from port P to A - B - T	l/min	1100
Ambient temperature range	°C	-20 / +50
Fluid temperature range	°C	-20 / +80
Fluid viscosity range	cSt	10 ÷ 400
Fluid contamination degree	according to ISO 4406:1999 class 20/18/15	
Recommended viscosity	cSt	25
Mass: DSP10		50
DSC10	kg	48

1 - IDENTIFICATION CODE FOR SOLENOID DISTRIBUTOR DSP10

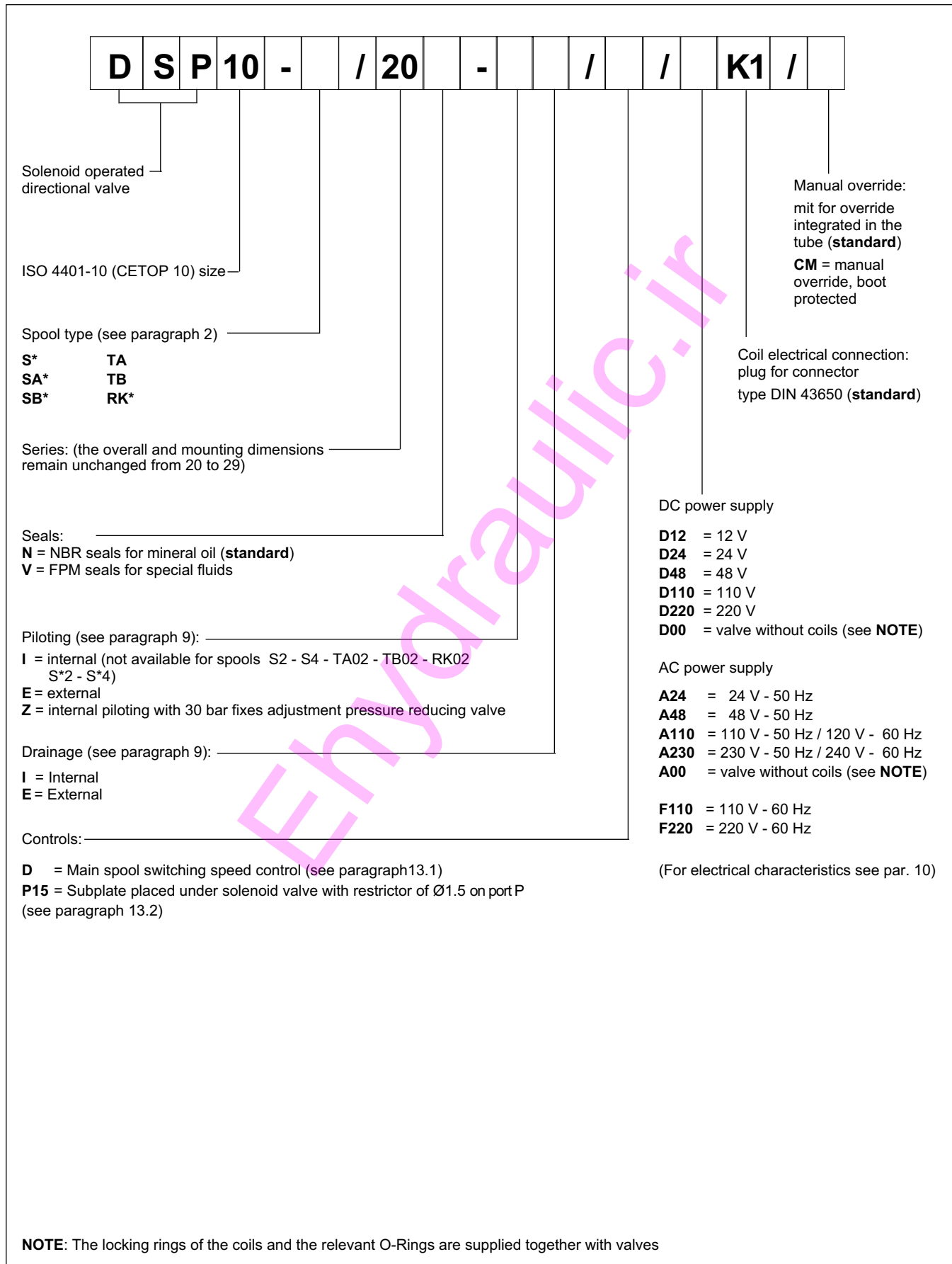

2 - SPOOL TYPE

NOTE: Symbols refers to the **DSP10** solenoid valve. For the **DSC10** hydraulic control version, please verify the connection scheme (see par. 3).

Type S*:
2 solenoids - 3 positions
with spring centering

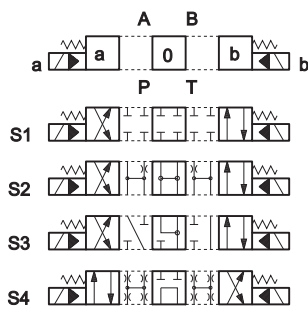

Type SA*:
1 solenoid side A
2 positions (central + external)
with spring centering

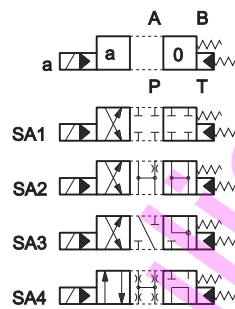

Type SB*:
1 solenoid side B
2 positions (central + external)
with spring centering

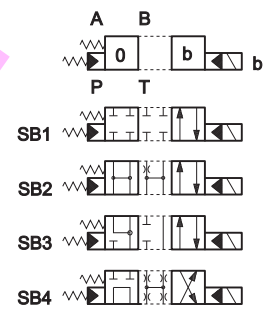

Type RK:
2 solenoids - 2 positions
with mechanical retention

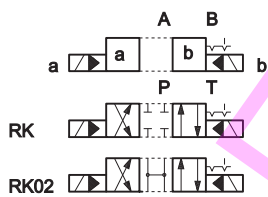

Type TA:
1 solenoid side A
2 external positions
with return spring

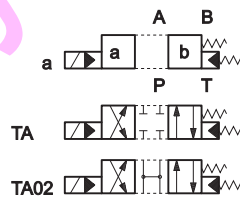

Type TB:
1 solenoid side B
2 external positions
with return spring

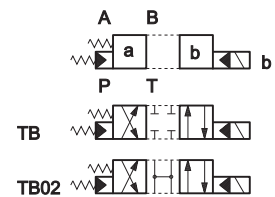

If other spool types are necessary please consult our Technical Department

3 - IDENTIFICATION CODE FOR HYDRAULIC DISTRIBUTOR DSC10

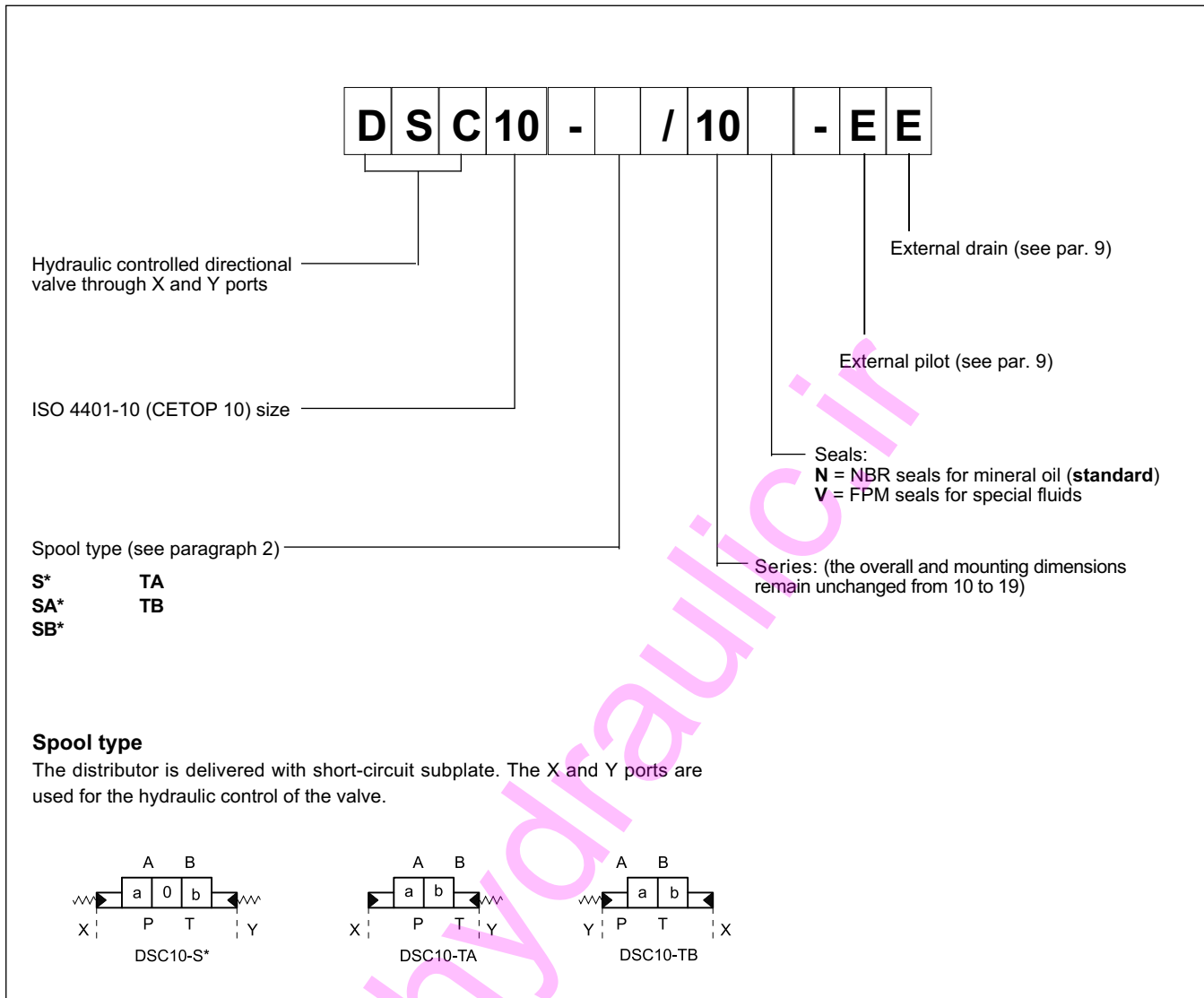

4 - HYDRAULIC FLUIDS

Use mineral oil-based hydraulic fluids HL or HM type, according to ISO 6743-4. For these fluids, use NBR seals (code V). For fluids HFDR type (phosphate esters) use FPM seals (code V). For the use of other kinds of fluid such as HFA, HFB, HFC, please consult our technical department. Using fluids at temperatures higher than 80 °C causes a faster degradation of the fluid and of the seals characteristics. The fluid must be preserved in its physical and chemical characteristics.

5 - PRESSURE DROPS Δp -Q (values obtained with viscosity 36 cSt at 50 °C)

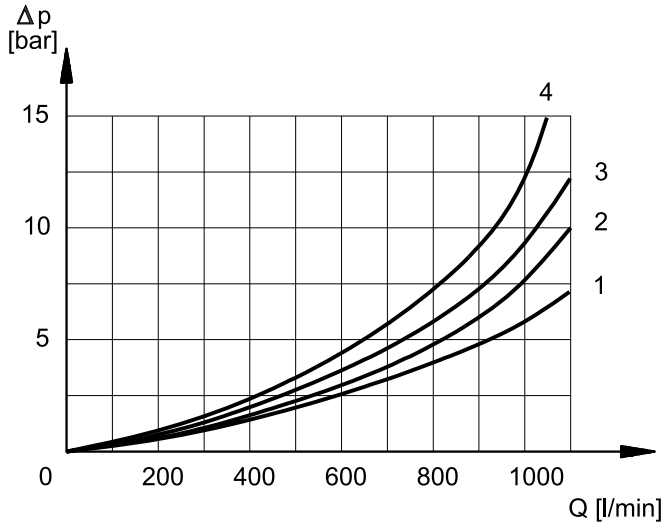

PRESSURE DROPS WITH VALVE ENERGIZED

SPOOL TYPE	FLOW DIRECTION			
	P-A	P-B	A-T	B-T
CURVES ON GRAPH				
S1, SA1, SB1	1	1	1	1
S2, SA2, SB2	2	2	2	2
S3, SA3, SB3	1	1	4	4
S4, SA4, SB4	2	2	2	2
TA, TB	1	1	1	1
TA02, TB 02	1	1	1	1
RK	1	1	1	1

PRESSURE DROPS WITH VALVE IN DE-ENERGIZED POSITION

SPOOL TYPE	FLOW DIRECTION				
	P-A	P-B	A-T	B-T	P-T
CURVES ON GRAPH					
S2, SA2, SB2					3
S3, SA3, SB3			4	4	
S4, SA4, SB4					4

6 - SWITCHING TIMES

The values indicated refer to a solenoid valve working with piloting pressure of 100 bar, with mineral oil at a temperature of 50°C, at viscosity of 36 cSt and with PA and BT connections. The energizing and de-energizing times are obtained at the pressure variation which occurs on the lines.

TIMES ($\pm 10\%$) [ms]	ENERGIZED		DE-ENERGIZED	
	2 Pos.	3 Pos.	2 Pos.	3 Pos.
	AC solenoid	90	60	90
DC solenoid	130	100	90	60

7 - OPERATING LIMITS

The curves define the flow rate operating fields according to the valve pressure of the different versions.

The values have been obtained according to ISO 6403 norm with solenoids at rated temperature and supplied with voltage equal to 90% of the nominal voltage.

The value have been obtained with mineral oil, viscosity 36 cSt, temperature 50 °C and filtration according to ISO 4406.1999 class 18/16/13.

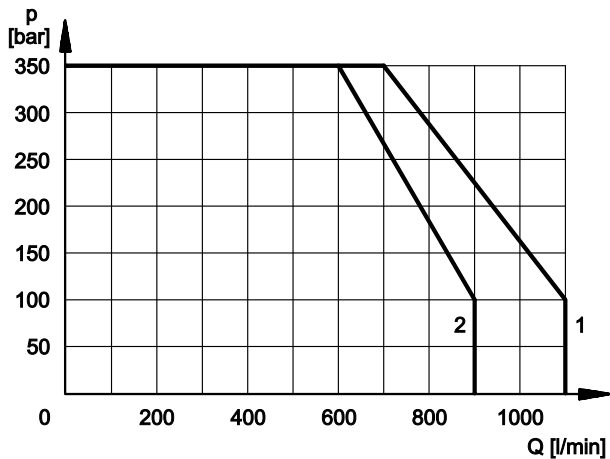

SPOOL TYPE	CURVE	
	P-A	P-B
S1, SA1, SB1	1	1
S2, SA2, SB2	2	2
S3, SA3, SB3	1	1
S4, SA4, SB4	2	2
TA, TB	1	1
TA02, TB02	1	1
TA23, TB23	1	1
RK	1	1

8 - PERFORMANCE CHARACTERISTICS

PRESSURES [bar]		
	MIN	MAX
Piloting pressure	12 (NOTE a)	280 (NOTE b)
Pressure on line T with internal drainage	-	140
Pressure on line T with external drainage	-	210

NOTES:

a) The minimum piloting pressure can be of 6 bar at low flows rates, but with higher flow rates a pressure of 12 bar is needed.

b) If the valve operates with higher pressures it is necessary to use the version with external pilot and reduced pressure. Otherwise, the valve with internal pilot and pressure reducing valve with 30 bar fixed adjustment can be ordered, inserting the letter Z in the code identification at piloting entry.

9 - PILOTING AND DRAINAGE

The DSP10 valves are available with piloting and drainage, both internal and external.

The version with external drainage allows for a higher back pressure on the outlet.

VALVE TYPE		Plug assembly	
		X	Y
IE	INTERNAL PILOT AND EXTERNAL DRAINAGE	NO	YES
II	INTERNAL PILOT AND INTERNAL DRAINAGE	NO	NO
EE	EXTERNAL PILOT AND EXTERNAL DRAINAGE	YES	YES
EI	EXTERNAL PILOT AND INTERNAL DRAINAGE	YES	NO

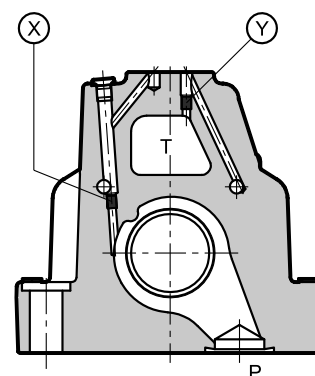

X: plug M6x8 for external pilot

Y: plug M6x8 for external drain

10 - ELECTRICAL FEATURES

10.1 - Solenoids

These are essentially made up of two parts: tube and coil. The tube is threaded into the valve body and includes the armature that moves immersed in oil, without wear. The inner part, in contact with the oil in the return line, ensures heat dissipation.

The coil is fastened to the tube by a threaded ring, and can be rotated 360°, to suit the available space.

NOTE 1: In order to further reduce the emissions, use of type H connectors is recommended. These prevent voltage peaks on opening of the coil supply electrical circuit (see CAT. 49 000).

NOTE 2: The IP65 protection degree is guaranteed only with the connector correctly connected and installed.

VOLTAGE SUPPLY FLUCTUATION	± 10% Vnom
MAX SWITCH ON FREQUENCY	6.000 ins/hr
DUTY CYCLE	100%
ELECTROMAGNETIC COMPATIBILITY (EMC) (NOTE 1)	In compliance with 2004/108/CE
LOW VOLTAGE	In compliance with 2006/95/CE
CLASS OF PROTECTION: Atmospheric agents (CEI EN 60529) Coil insulation (VDE 0580) Impregnation: DC valve AC valve	IP 65 (NOTE 2) class H class F class H

10.2 - Current and absorbed power for DC solenoid valve

The table shows current and power consumption values relevant to the different coil types for DC.

The rectified current supply takes place by fitting the valve (with the exception of D12 coil) with an alternating current source (50 or 60 Hz), rectified by means of a bridge built-in to the "D" type connectors (see cat.49 000), by considering a reduction of the operating limits by 5 + 10% approx.

Coils for direct current (values ± 5%)

Suffix	Nominal voltage [V]	Resistance at 20°C [Ω]	Current consumpt. [A]	Power consumpt. [W]	Coil code
D12	12	4,4	2,72	32,6	1902860
D24	24	18,6	1,29	31	1902861
D48	48	78,6	0,61	29,3	1902863
D110	110	423	0,26	28,6	1902864
D220	220	1692	0,13	28,6	1902865

10.3 - Current and absorbed power for AC solenoid valve

The table shows current and power consumption values at inrush and at holding, relevant to the different coil types for AC current.

Coils for alternating current (values ± 5%)

Suffix	Nominal voltage [V]	Frequency [Hz]	Resistance at 20°C [ohm]	Current consumption at inrush [A]	Current consumption at holding [A]	Power consumption at inrush [VA]	Power consumption at holding [VA]	Coil code
A24	24	50	1,46	8	2	192	48	1902830
A48	48	50	5,84	4,4	1,1	204	51	1902831
A110	110V-50Hz	50/60	32	1,84	0,46	192	48	1902832
	120V-60Hz			1,56	0,39	188	47	
A230	230V-50Hz		140	0,76	0,19	176	44	1902833
	240V-60Hz			0,6	0,15	144	36	
F110	110	60	26	1,6	0,4	176	44	1902834
F220	220	60	106	0,8	0,2	180	45	1902835

11 - OVERALL AND MOUNTING DIMENSIONS FOR SOLENOID DISTRIBUTOR DSP10

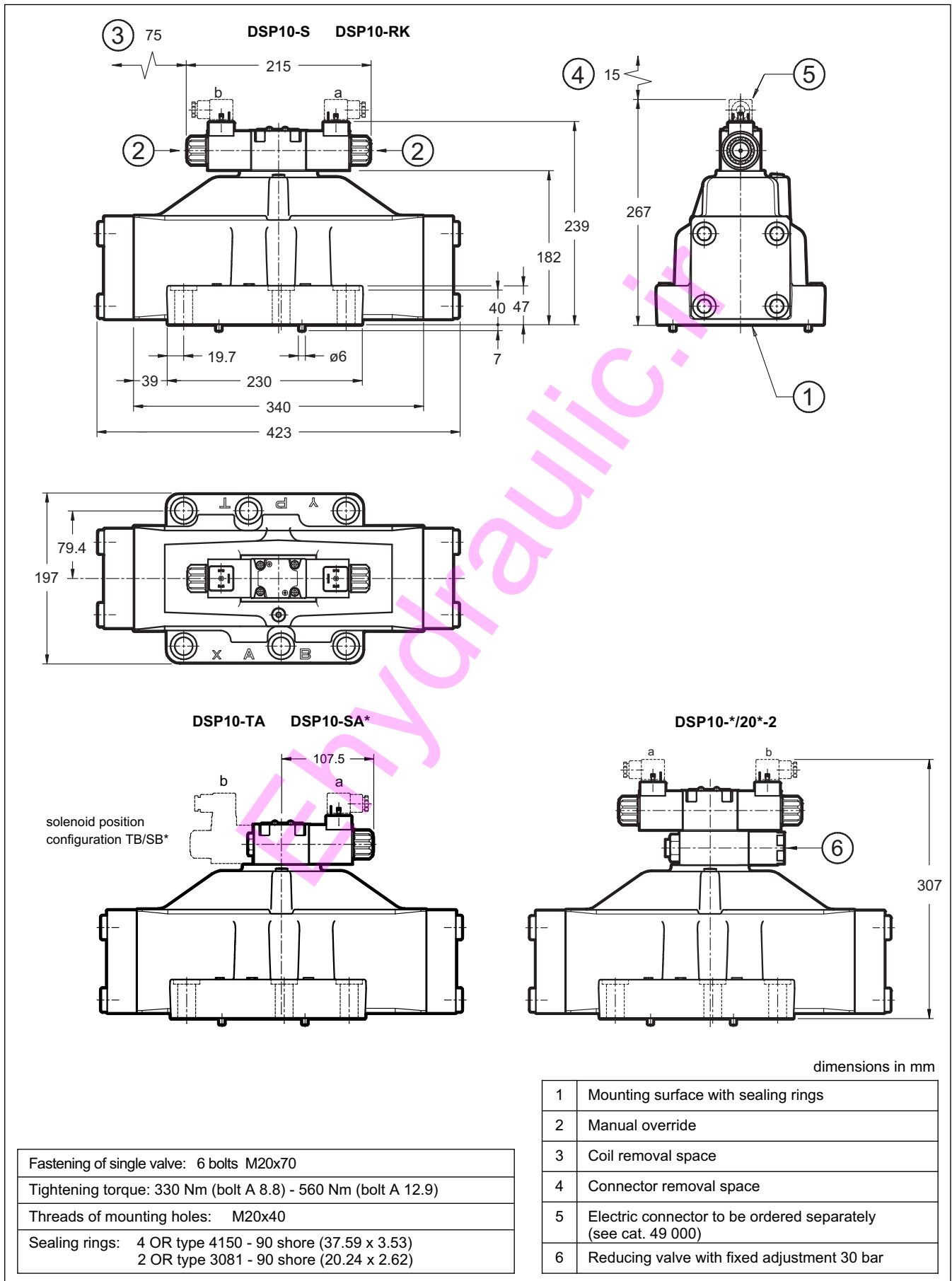

12 - OVERALL AND MOUNTING DIMENSIONS FOR HYDRAULIC DISTRIBUTOR DSC10

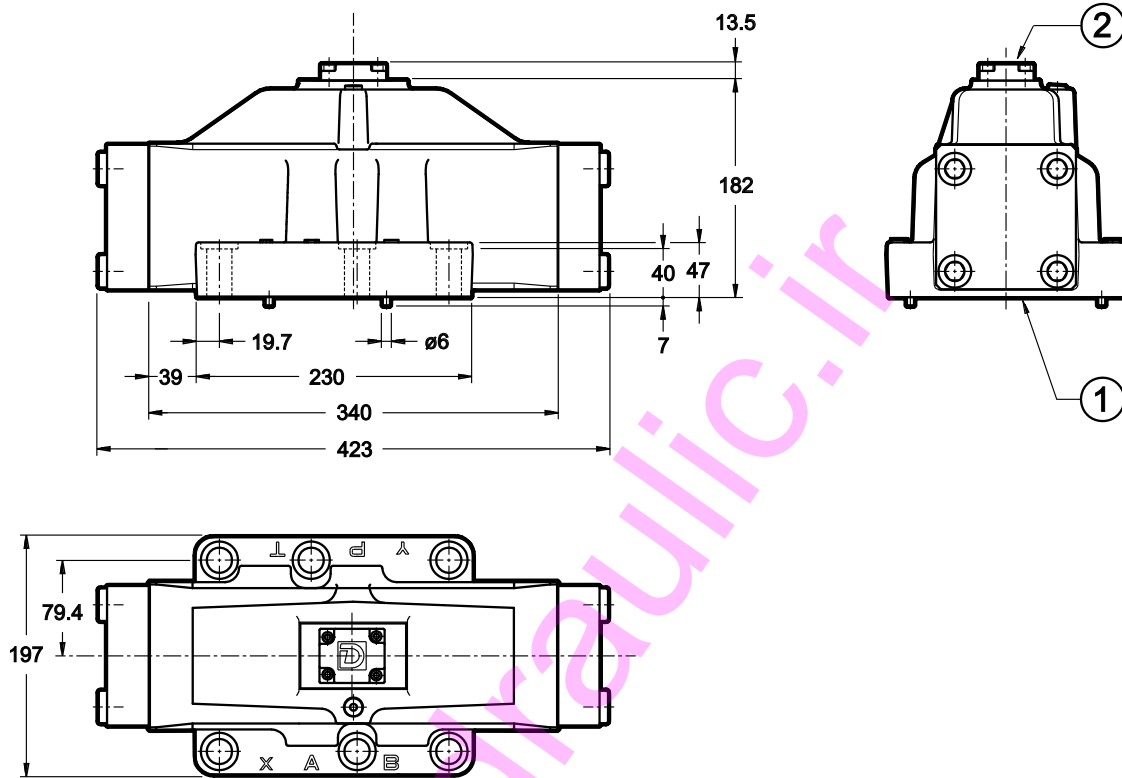

dimensions in mm

Fastening of single valve: 6 bolts M20x70
Tightening torque: 330 Nm (bolt A 8.8) - 560 Nm (bolt A 12.9)
Threads of mounting holes: M20x40
Sealing rings: 4 OR type 4150 - 90 shore (37.59 x 3.53) 2 OR type 4075 - 90 shore (20.24 x 2.62)

1	Mounting surface with sealing rings
2	Short-circuit subplate

13 - OPTIONS

13.1 - Control of the main spool shifting speed: D

By placing a MERS type double flow control valve between the pilot solenoid valve and the main distributor, the piloted flow rate can be controlled and therefore the changeover smoothness can be varied.

Add the letter **D** to the identification code to request this device (see paragraph 1).

DSP10-S*/D

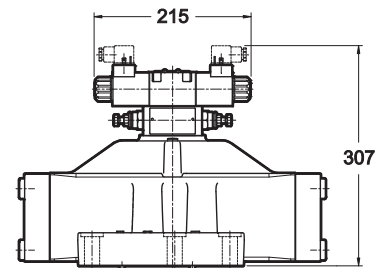

13.2 - Subplate with throttle on line P

It is possible to introduce a subplate with a restrictor of $\varnothing 1,5$ on line P between the pilot solenoid valve and the main distributor.

Add **P15** to the identification code to request this option (see paragraph 1).

DSP10-S*/P15

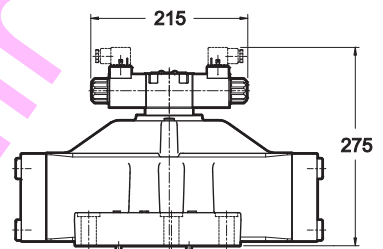

14 - MANUAL OVERRIDE, BOOT PROTECTED: CM

Whenever the solenoid valve installation may involve exposure to atmospheric agents or use in tropical climates, the manual override, boot protection is recommended.

Add the suffix **CM** to request this device (see paragraph 1).

For overall dimensions see cat. 41 150.

15 - ELECTRIC CONNECTORS

The solenoid operated valves are delivered without the connectors. They must be ordered separately.

For the identification of the connector type to be ordered, please see catalogue 49 000.

16 - INSTALLATION

Configurations with centering and recall springs can be mounted in any position; type RK valves - without springs and with mechanical detent - must be mounted with the longitudinal axis horizontal.

Valve fastening takes place by means of screws or tie rods, laying the valve on a lapped surface, with values of planarity and smoothness that are equal to or better than those indicated in the drawing.

If the minimum values of planarity or smoothness are not met, fluid leakages between valve and mounting surface can easily occur.

