



PCK06

TWO- AND THREE-WAY PRESSURE COMPENSATOR WITH FIXED OR VARIABLE ADJUSTMENT SERIES 10

CARTRIDGE TYPE

p max 350 bar

Q max 40 l/min

SEAT DIMENSIONS D-10D

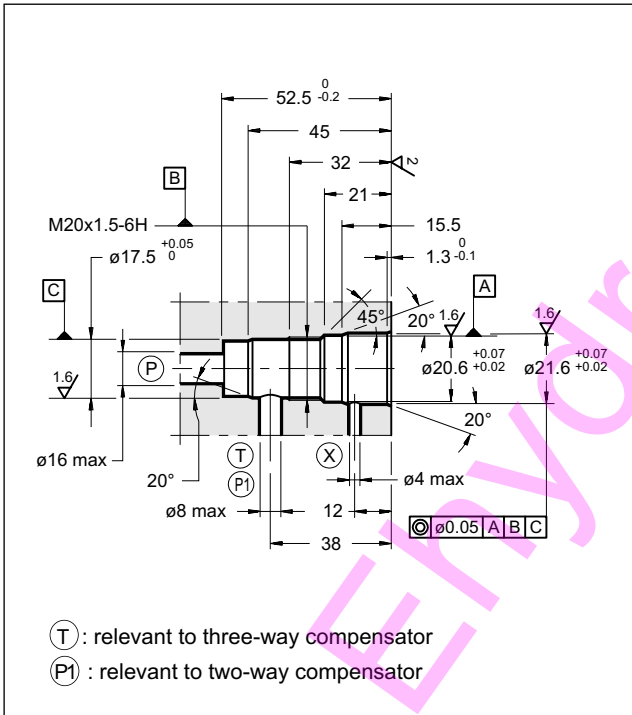

OPERATING PRINCIPLE

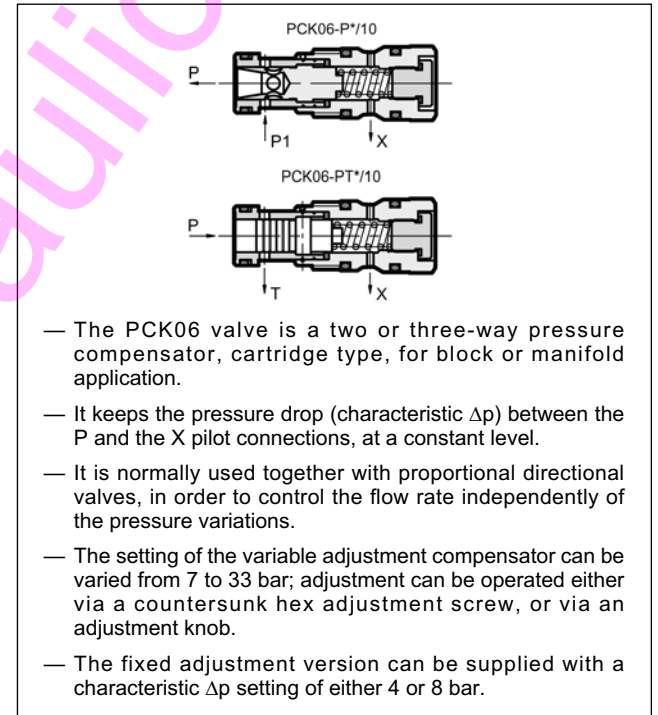

PERFORMANCES (working with mineral oil of viscosity of 36 cSt a 50°C)

Maximum operating pressure	bar	350
Characteristic Δp : fixed adjustment	bar	4 - 8
variable adjustment	bar	7 ÷ 33
Maximum flow rate	l/min	40
Ambient temperature range	°C	-20 / +50
Fluid temperature range	°C	-20 / +80
Fluid viscosity range	cSt	10 ÷ 400
Fluid contamination degree	According to ISO 4406:1999 class 20/18/15	
Recommended viscosity	cSt	25
Mass:	kg	0,2
Surface treatment : electrolytic zinc covering	Fe // Zn 8 // B EN 12329	

HYDRAULIC SYMBOLS

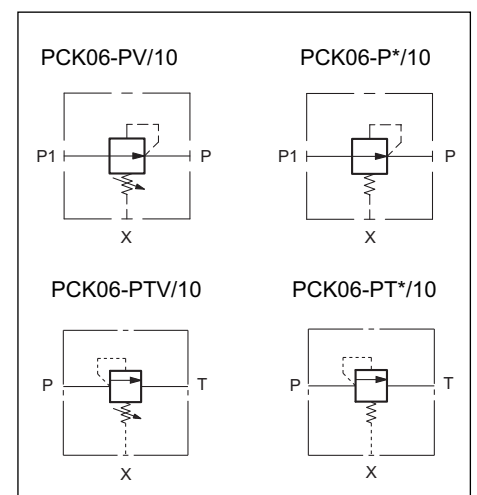

1 - IDENTIFICATION CODE

1.1 - Two-way compensator identification code

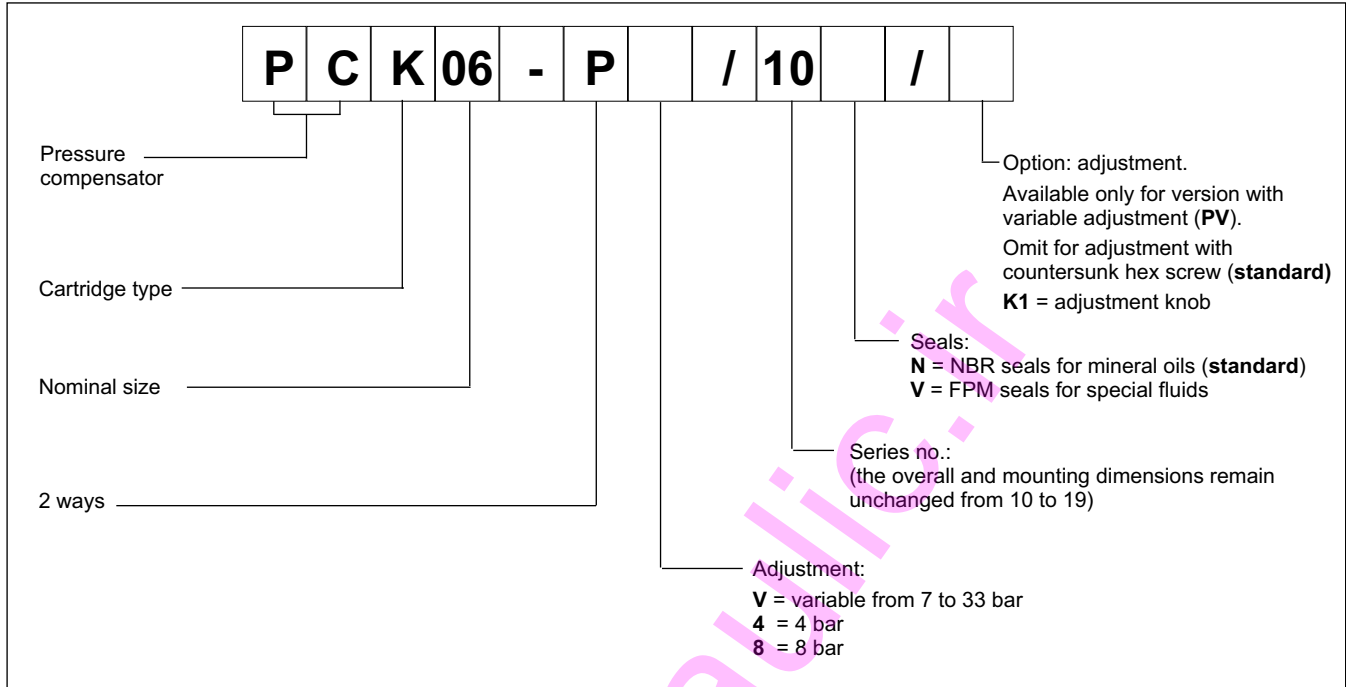

1.2 - Three-way compensator identification code

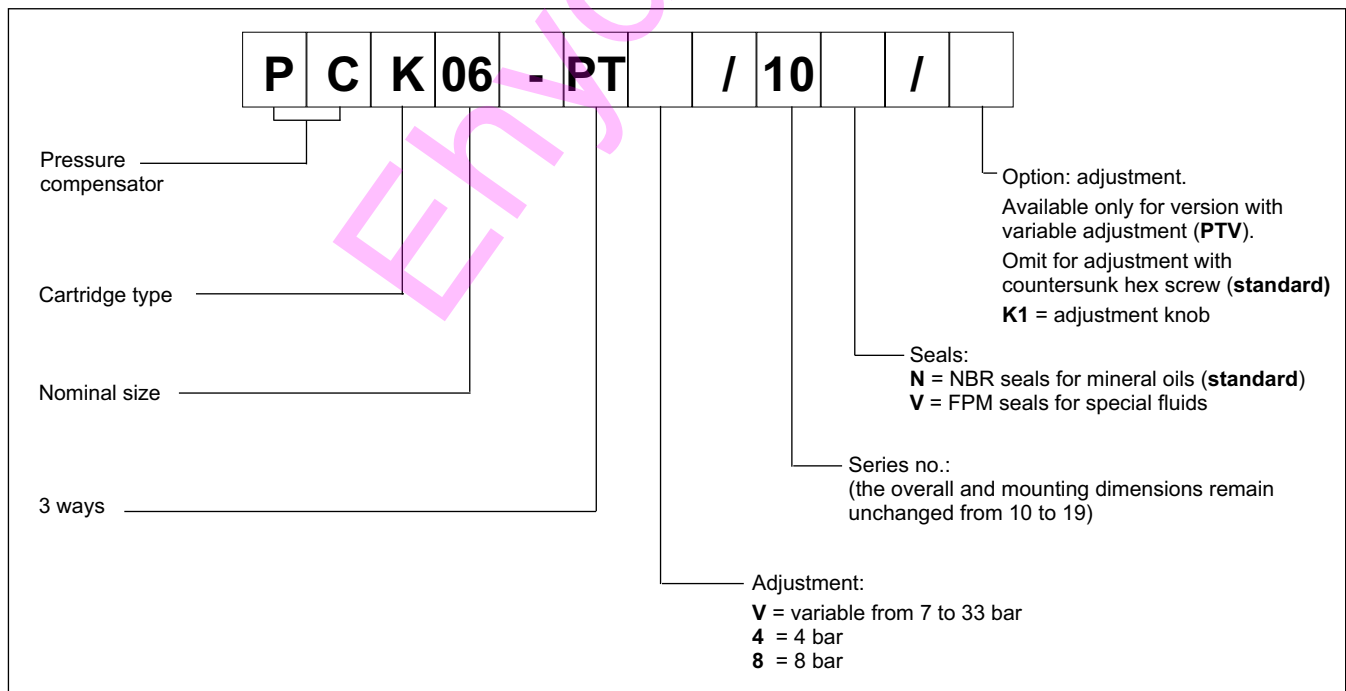

2 - CHARACTERISTIC CURVES (values obtained with viscosity of 36 cSt at 50°C)

2.1 - Two-way compensator characteristic curves

FLOW RATE - PRESSURE $Q = f(p)$

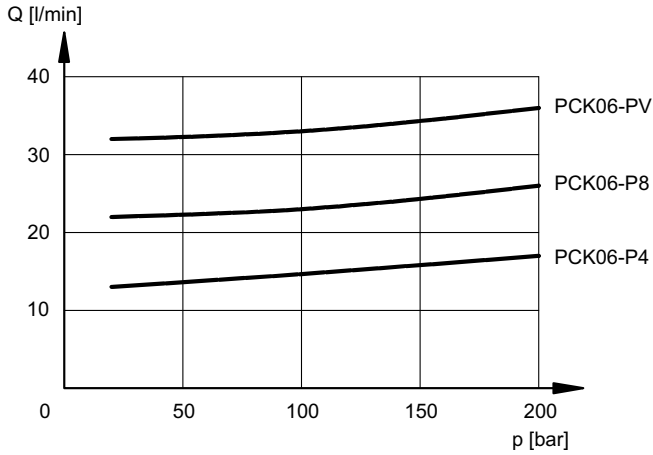

PRESSURE DROPS $\Delta p = f(Q)$

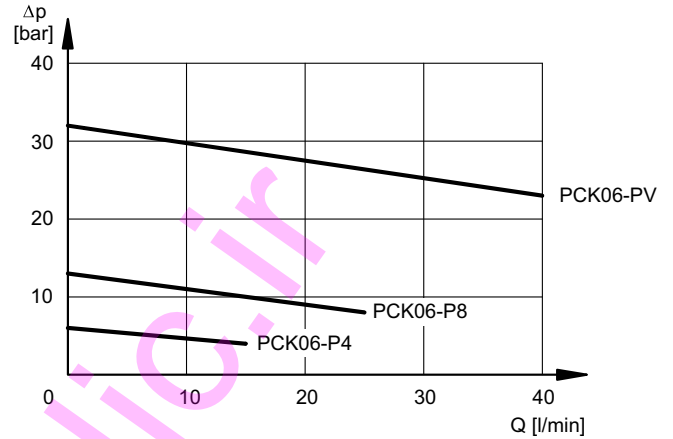

2.2 - Three-way compensator characteristic curves

FLOW RATE - PRESSURE $Q = f(p)$

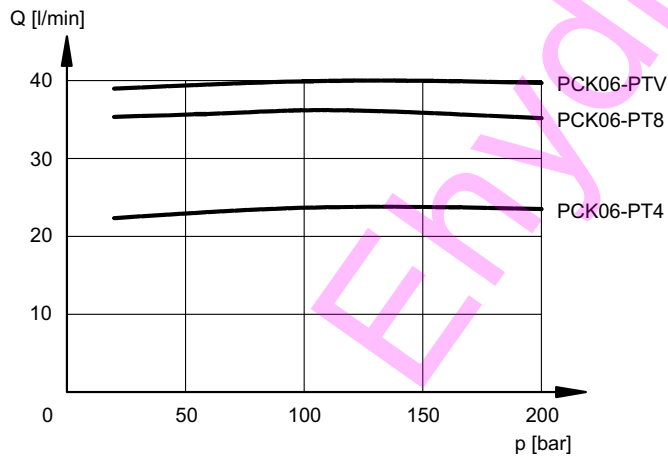

PRESSURE DROPS $\Delta p = f(Q)$

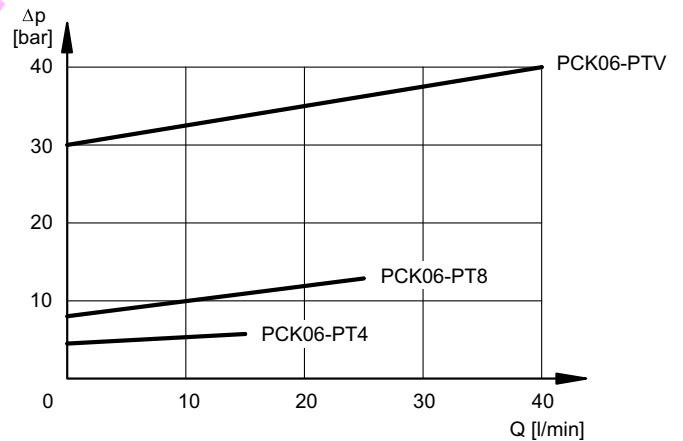

3 - HYDRAULIC FLUIDS

Use mineral oil-based hydraulic fluids HL or HM type, according to ISO 6743-4. For these fluids, use NBR seals (code N). For fluids HFDR type (phosphate esters) use FPM seals (code V). For the use of other kinds of fluid such as HFA, HFB, HFC, please consult our technical department. Using fluids at temperatures higher than 80 °C causes a faster degradation of the fluid and of the seals characteristics. The fluid must be preserved in its physical and chemical characteristics.

4 - OVERALL AND MOUNTING DIMENSIONS

PCK06-P*/10
PCK06-PT*/10

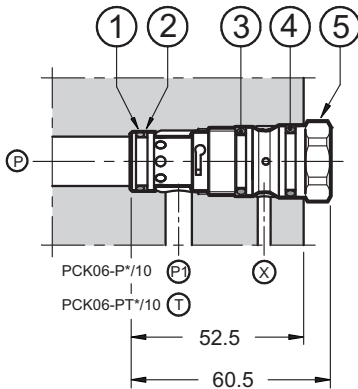

PCK06-PV/10
PCK06-PTV/10

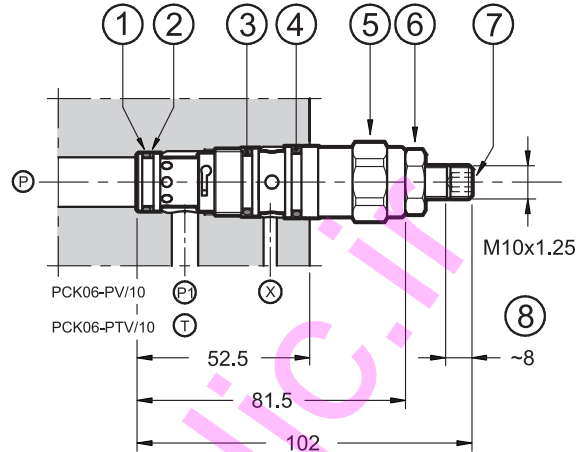

PCK06-PV/10*/K1
PCK06-PTV/10*/K1

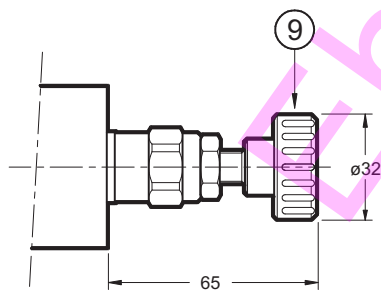

dimensions in mm

1	OR type 2056 (14.00x1.78)
2	Parbak 8-015 (14.81x1.14x1.35)
3	OR type 3062 (15.54x2.62)
4	OR type 3062 (15.54x2.62)
5	Hexagonal: spanner 22 Tightening torque 45 ÷ 50 Nm
6	Locking nut: spanner 17
7	Countersunk hex adjustment screw: spanner 5 Clockwise rotation to increase pressure
8	Maximum screw stroke
9	Adjustment knob: K1